

Universal Product Stacker

Fully Automatic Output Product Stacker
For Media, Cosmetics, Pharmaceuticals



Universal Product Stacker

This automated system stacks products in pre-configurable stack sizes. The system can be used to stack a continuous feed of products traveling along a conveyor line into vertical stacks, saving space and facilitating the packing of products into shipping boxes. Products accumulate on the in-feed conveyor during ejection cycles, enabling the system to handle 70 products per minute without pause. This feature enables the DMA stacker to be incorporated into almost any continuous packaging line. Adjustments can be made in minutes to accommodate products of various sizes.

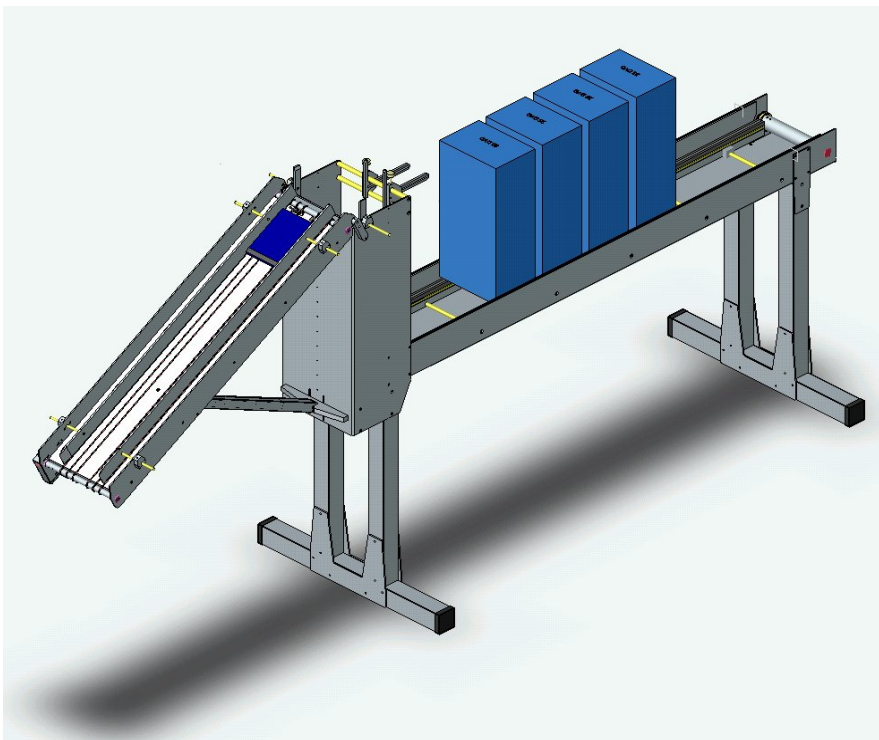

**Universal Servo
Product Stacker
Showing Products
Stacked on Out-
Feed Conveyor
and One Product
on In-Feed
Conveyor**

Automated Product Stacker Specifications:

- Product Sizes:

Maximum Width:	8.5 inches
Maximum Length:	6.0 inches
Maximum Height:	3.0 inches
Minimum Width:	2.0 inches
Minimum Length:	2.0 inches
Minimum Height:	.05 inches

Note: The sizes listed encompasses: Blu-ray, DVD, CD, DS Amaray and more.

- Stack Height:

Maximum:	18 inches
Minimum:	1 inch
Typically	5 to 15 Cases
- Speed: Approximately 70 parts per minute
- Physical Size: 18" W, x 60" L, x 38" H
- Stand Height: Adjustable
- Electrical Connectivity: Regular 110/220 VAC wall outlet
- Pneumatic Connectivity: 70~120psi (0.1 SCFM)
All electrical models that do not require pneumatic supply are optional
- Interface: Full easy interface to other equipment
- Product entry: In-feed conveyor
- Optional: Extended out-feed conveyor
- Optional: Bar-Code reader to verify product ID

Digital Media Automation Incorporated
12815 Stone Canyon Road, Poway, CA 92064, USA
Tel: (858) 673-8505 Internet: www.dmaut.com