



Presto Modular Automated Media Packaging Line



& Standard DVD Compatible

The Presto Line of automated stand-alone packaging systems is a highly efficient modular solution to automate all phases of media packaging. Each module can be used independently in a semi automatic capacity, or all modules can be utilized in conjunction to fully automate the entire packaging line. A

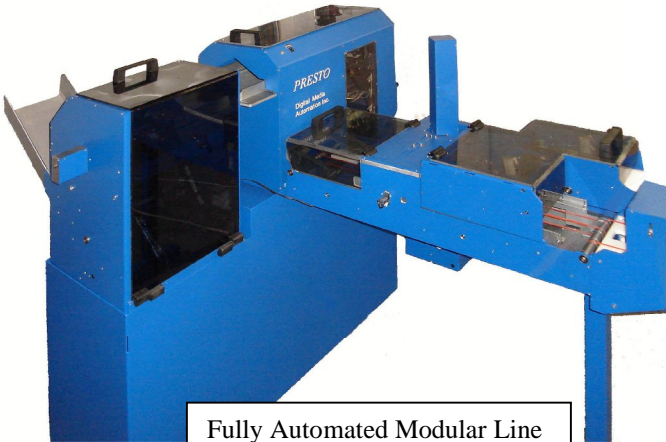

Fully Automated Modular Line

complete fully automated line consists of five modules. The modules are: Case Opener and Presenter, Slipsheet Inserter, Disc Placer, Booklet Placer, and finally a Case Closer Module.



Title Sheet Insertion Module: Semi Automatic When Used Standalone

At the core of the packaging line is the Presto Inserter, which inserts a title sheet. In the semi automatic capacity an operator opens and inserts cases into the Presto Inserter. The system then inserts a title sheet into the case and ejects the case from the side of the machine. This step increases operator efficiency by as much as 500%. An increased level of automation is accomplished when cases are fed automatically from the Automated Case Feeder. Multiple discs and internal booklets can be placed as needed before automatically outputting cases.

Module Description

Presto Title Sheet Inserter:

The Presto Inserter Inserts title sheets into the cases. Up to 600 title sheets are loaded into the Inserter Hopper. Cases are fed into the inserter one title sheet is loaded under the clear film of each case prior to ejecting cases from the side of the system. The cases can be fed in a semi automatic capacity by an operator, or in a fully automatic capacity by the Case Feeder Module.

Presto Case Feeder:

The Case Feeder can be positioned in line with the Presto Inserter to automatically open and insert each case into the Presto Inserter. Closed cases are loaded into a hopper. The system opens each case and inserts them into the Presto Inserter automatically. An extended in-feed hopper accommodates approximately 200 cases at a time.

Presto Disc Placer:

Discs are loaded on industry standard spindles into the Disc Placer Module. Cases dropped onto the Presto Disc Placer conveyor are indexed to the disc placing position where one disc is placed into each case in any of the standard hub positions. Multiple Presto Disc Placers can be positioned inline to place any number of discs into each case. The Presto Disc Placer can also be used to place discs in CD Jewel Cases, Cardboard DigiPack Trays.

Presto Booklet / Coupon Inserter:

An automated coupon placer can be positioned in-line with the system to place any number of internal coupons / booklets in each case. Coupons are loaded into a bulk hopper from which the system places coupons in each case.

Presto Case Closer:

Cases can finally either be closed by hand, or for a greater level of efficiency, automatically using the Presto Case Closer. Beyond HD DVD / Blu-Ray, DS Amaray and standard DVD formats, the Presto Case Closer will automatically also close CD jewel cases, Super Jewel Cases, Paperboard DigiPacks, and Slimline cases.

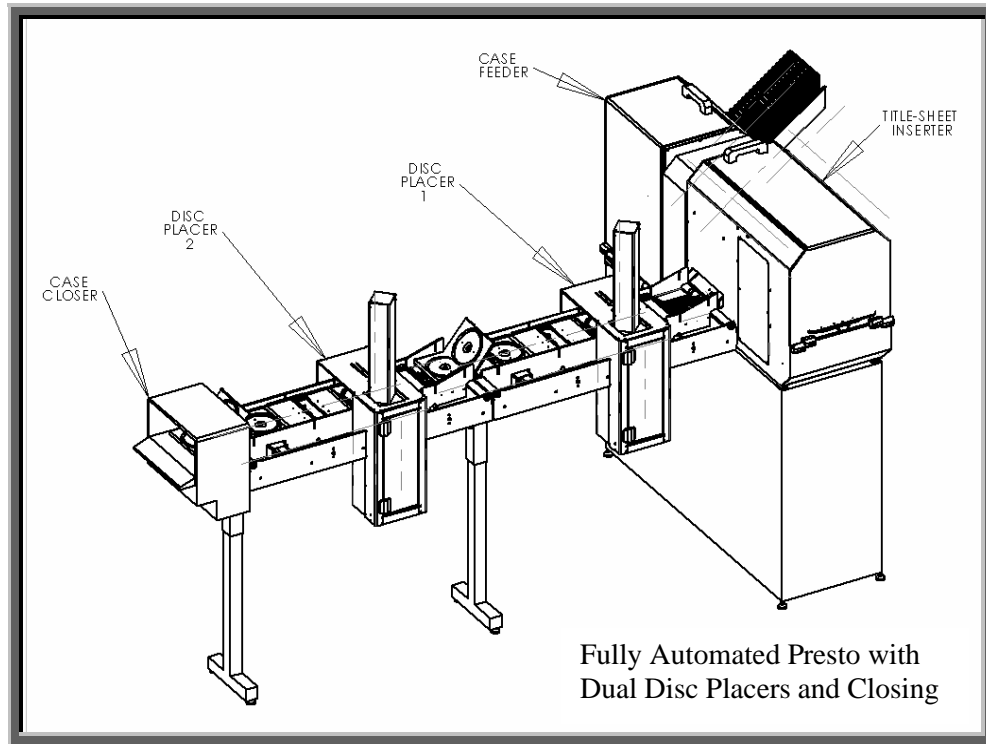

Presto Line Specifications:

- **Formats Compatibility:** Virtually all Amaray: Slimline, Standard, Jumbo, Blu-Ray, HD-DVD, DS Amaray Cases

Note:

The Presto Disc Placer and Presto Case Closer also supports CD Jewel Cases, Super Jewel Cases, and paperboard Digipacks.

- **Each Module's Speed:** 30 cases per minute
- **Connectivity:** Electric, Regular Outlet 110 or 220 V
Pneumatic, 90 psi

Digital Media Automation Incorporated
12815 Stone Canyon Road, Poway, CA 92064, USA
Tel: (858) 673-8505 Internet: www.dmaut.com